

Mamba Digital Snake Manual

Connecting the Mamba with Micpre:

Point to Point:

Connect all your inputs such as Microphones, instruments and CD players etc on Micpre inputs which is XLR/TRS combo. From the back side of the micpre, connect a DB25 - TRS breakout cable (for PR8E) or DB25 - XLR F (for EP84) from the outputs (channels 1-8) to Mamba stage box inputs. The 8 channel DB25 breakout cable is ideal for each micpre box to Inputs on Mamba stage box.

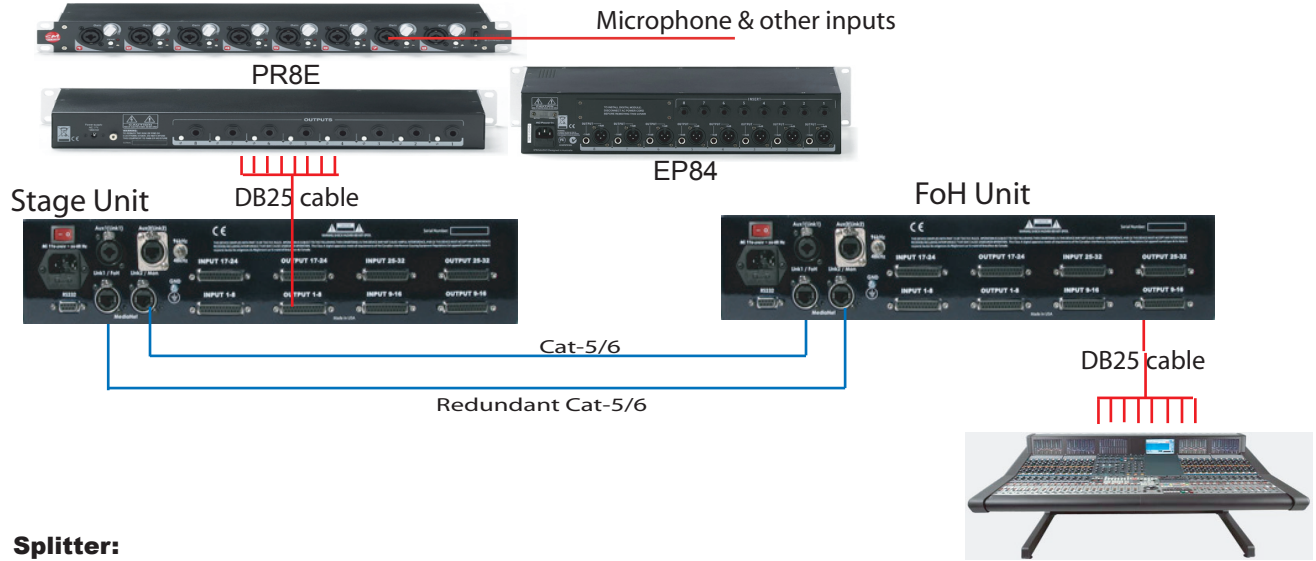

Splitter:

For splitter setup, follow the below diagram. The FoH unit CAT-5 cable connects to the Link1/FoH port on the stage box. The Mon Mix unit CAT-5 connects to the Link 2/Mon port on the stage box. The channels from Stage box is sent to FoH and Mon as split. The split is done in digital domain so latency is same and signal is identical at all receivers.

The returns at the stage box are configured as follows:

- 16X8X8: Outputs 1-8 are Returns from FoH (Link1/FoH) & Outputs 9-16 are Returns from Mon Mix
- 32X16X16: Outputs 1-16 are Returns from FoH (Link1/FoH) & Outputs 17-32 are Returns from Mon Mix
- 48X24X24: Outputs 1-24 are Returns from FoH (Link1/FoH) & Outputs 25-48 are Returns from Mon Mix
- 64X32X32: Outputs 1-32 are Returns from FoH (Link1/FoH) & Outputs 33-64 are Returns from Mon Mix

